

SECURE SERIES™

The Newest Innovation from NORELL®

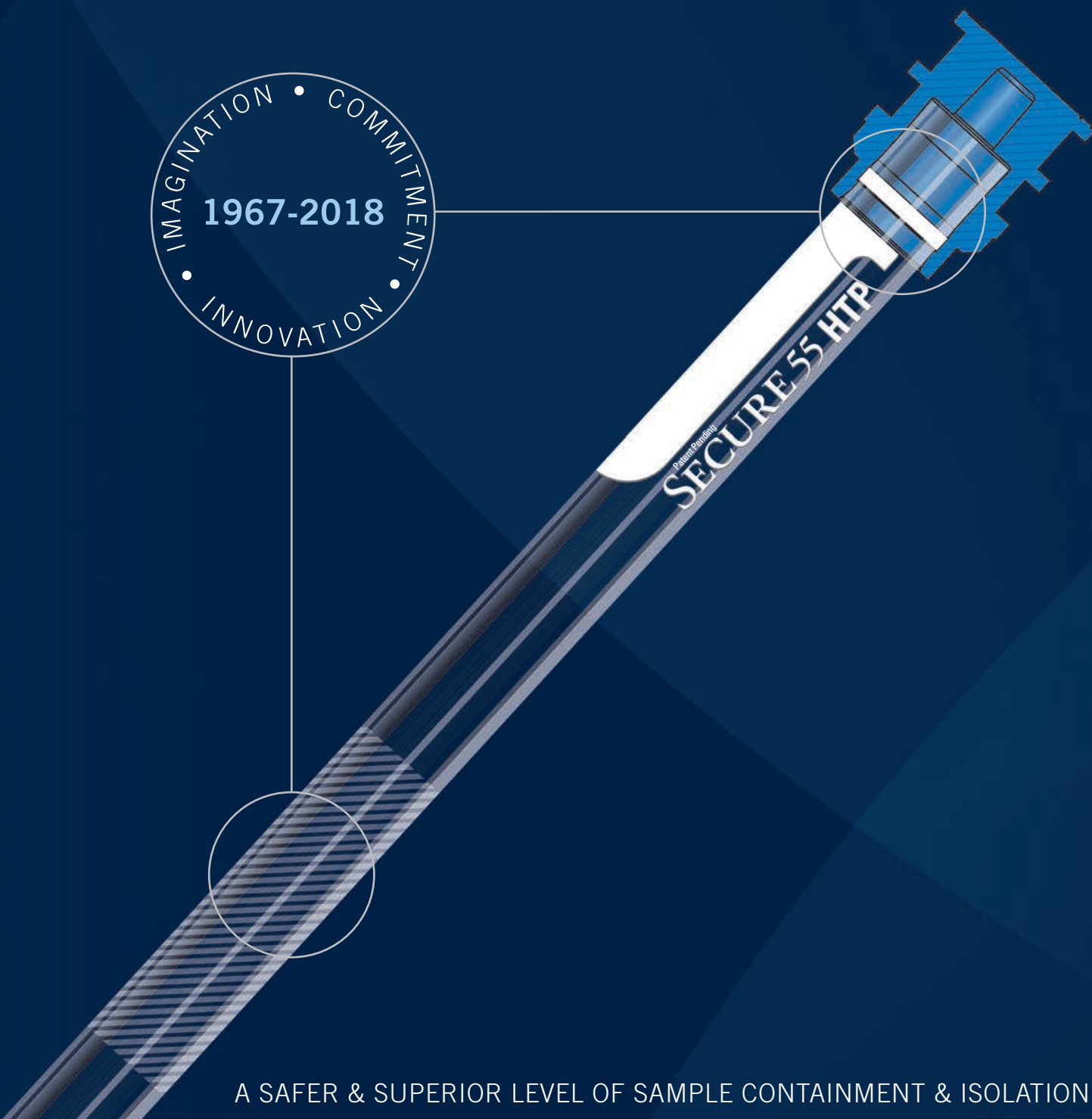

A SAFER & SUPERIOR LEVEL OF SAMPLE CONTAINMENT & ISOLATION

Distributed by



NORELL® SECURE SERIES™ NMR Sample Tubes and the NORELL® NorLoc™ Generation II Security Cap™

PAT8054080

Norell, Inc. is pleased to introduce the newest innovation in 5mm and 3mm OD NMR tubes and closures: the NORELL® Secure Series™ line of NMR tubes paired with the NORELL® NorLoc II Security Cap™.

The Secure Series™ NMR tubes feature several Patent Pending design elements that add a superior level of sample containment and isolation, safeguarding the integrity of precious or critical NMR samples and assuring secure retention of the NMR tube in the spinner turbine.

The NORELL® Secure Series™ NMR Sample Tubes Include:

Security Band

- A Patent Pending Security Band™ that engages and locks into the NorLoc II Security Cap™, securely joining the cap to the NMR tube.
- The edge of the Security Band™ also denotes a stop position for partial, temporary cap placement, allowing quick and easy access to the NMR tube.
- A Patent Pending proprietary surface treatment with a unique textured surface ensures precise and positive retention in Bruker, Agilent/Varian and Jeol spinner turbines.
- A Patent Pending marking or label area that also functions as a clear visual indicator, defining the limit for full and complete closure with the NorLoc II Security Cap™.

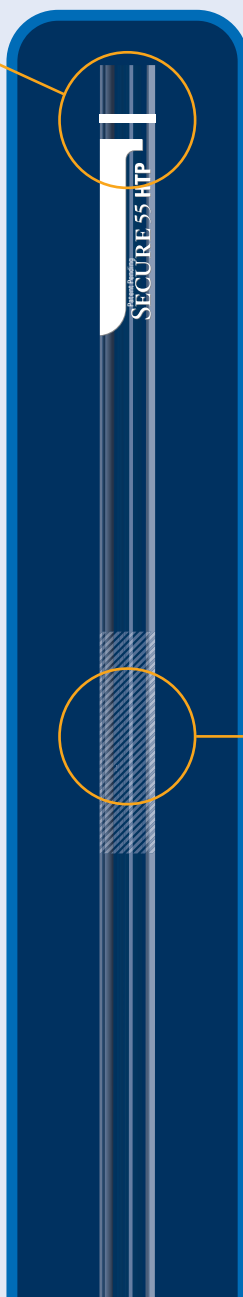

- The Secure Series™ NMR tubes are available in two types: the Secure 33 Series™ and the Secure 55 Series™ in both 178mm and 203mm lengths.
- The Secure 33 Series™ NMR tubes are made from ASTM Type I Class A borosilicate glass (Pyrex® 7740 or equivalent) and have comparable glass properties to the Norell Select Series™ NMR tubes.
- The Secure 55 Series™ NMR tubes are made from ASTM Type I Class B borosilicate glass (N-51A or equivalent) and have comparable glass properties to the Norell Standard Series™ NMR tubes.
- The Secure Series™ NMR tubes remain completely compatible with standard, classic NMR tube caps in both 5mm and 3mm sizes.

Proprietary Surface Treatment for Secure Turbine Retention

NORELL® Secure Series NMR Sample Tubes and NORELL® NorLoc™ Generation II Security Caps - *Reliability, Safety and Versatility*

PAT8054080

The NORELL® NorLoc™ Generation II Security Cap™ Includes:

- An internal Patent Pending Security Seal™ that provides superior hermetic sealing capability on all 5mm and 3mm NMR tubes.
- The NorLoc II Security Cap™ requires much less force to place on or remove from an NMR tube, thereby greatly advancing the level of safety when capping NMR tubes.
- When combined with a Secure Series™ or other Norell NMR tube, the Security Band™ and Security Seal™ interlock to form a positive physical restraint system, preventing tube and cap separation, especially with troublesome NMR solvents such as chloroform-d.

STAGE I

For all Bruker / Agilent-Varian / Jeol spinner turbine based NMR Spectrometers:

Our dual purpose proprietary security band allows safe, reliable and secure placement of the NorLoc II cap. Simply align the specially enlarged cap opening with the NMR tube and lightly push the cap to the natural stop created by the security band. The ensuing placement and single stage seal is a novel progression in lab safety with enhanced performance and ergonomic feel.

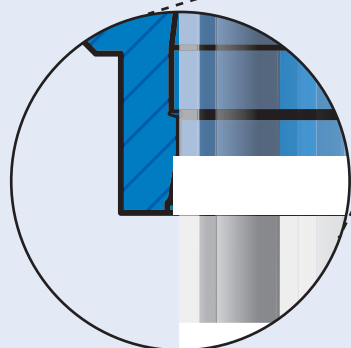

NorLoc Generation II Caps are specifically designed to work with NORELL Secure Series™ Sample Tubes.

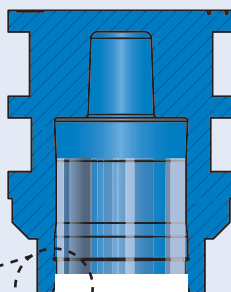

STAGE II

For Bruker Sample Jet Systems

For Bruker Sample Jet use, simply apply additional pressure on the NorLoc II cap to engage the cap's locking mechanism onto the tube's security band. You will know that the cap is properly engaged when the bottom of the cap touches our exterior tube marking area. Our dual stage mechanism provides superior hermetic sealing and the interlock forms a positive physical restraint system preventing tube and cap separation especially with troublesome NMR solvents such as chloroform-d.

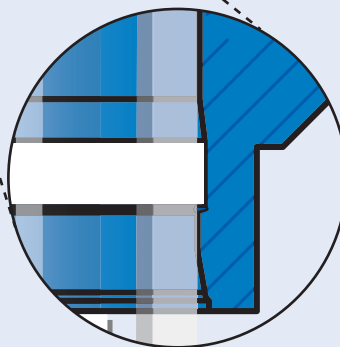
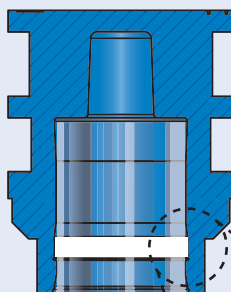

The Secure 33 Series™ NMR Sample Tubes for High Resolution NMR

The Secure 33 Series™ NMR tubes are made from ASTM Type I Class A borosilicate glass (“low expansion” borosilicate glass such as Corning Pyrex® 7740 or equivalent) and match the properties of the Select Series™ NMR tubes from Norell. Because of the low coefficient of thermal expansion, Secure 33 Series™ NMR tubes show a high degree of thermal shock resistance, a necessary attribute to prevent breakage when large temperature variations are expected in variable temperature studies, degassing samples through freeze-pump-thaw cycles, etc.

5mm Ultra-Precision NMR Sample Tubes



Item No.	Spinner Turbine	MHz	O.D. (mm)	I.D. (mm)	Concentricity (mm)	Camber ±(mm)	Length (mm)	Packed In Lots Of
C-S33-1000-050-1780	Bruker	1000	4.97 ± 0.003	4.20 ± 0.006	0.0018	0.0027	178	5
C-S33-1000-050-2030	Agilent/Varian	1000	4.97 ± 0.003	4.20 ± 0.006	0.0018	0.0027	203	5
C-S33-0900-050-1780	Bruker	900	4.97 ± 0.004	4.20 ± 0.006	0.0020	0.0030	178	5
C-S33-0900-050-2030	Agilent/Varian	900	4.97 ± 0.004	4.20 ± 0.006	0.0020	0.0030	203	5
C-S33-0800-050-1780	Bruker	800	4.97 ± 0.005	4.20 ± 0.012	0.0025	0.0038	178	5
C-S33-0800-050-2030	Agilent/Varian	800	4.97 ± 0.005	4.20 ± 0.012	0.0025	0.0038	203	5
C-S33-0600-050-1780	Bruker	600	4.97 ± 0.006	4.20 ± 0.012	0.0040	0.0060	178	5
C-S33-0600-050-2030	Agilent/Varian	600	4.97 ± 0.006	4.20 ± 0.012	0.0040	0.0060	203	5
C-S33-0500-050-1780	Bruker	500	4.97 ± 0.013	4.20 ± 0.025	0.0050	0.0130	178	5
C-S33-0500-050-2030	Agilent/Varian	500	4.97 ± 0.013	4.20 ± 0.025	0.0050	0.0130	203	5
C-S33-0400-050-1780	Bruker	400	4.97 ± 0.013	4.20 ± 0.025	0.0070	0.0190	178	5
C-S33-0400-050-2030	Agilent/Varian	400	4.97 ± 0.013	4.20 ± 0.025	0.0070	0.0190	203	5
C-S33-0300-050-1780	Bruker	300	4.97 ± 0.025	4.20 ± 0.025	0.0070	0.0250	178	5
C-S33-0300-050-2030	Agilent/Varian	300	4.97 ± 0.025	4.20 ± 0.025	0.0070	0.0250	203	5
C-S33-0200-050-1780	Bruker	200	4.97 ± 0.030	4.20 ± 0.030	0.0090	0.0350	178	5
C-S33-0200-050-2030	Agilent/Varian	200	4.97 ± 0.030	4.20 ± 0.030	0.0090	0.0350	203	5

3mm Ultra-Precision NMR Sample Tubes

Item No.	Spinner Turbine	MHz	O.D. (mm)	I.D. (mm)	Concentricity (mm)	Camber ±(mm)	Length (mm)	Packed In Lots Of
C-S33-1000-030-1780	Bruker	1000	2.99 ± 0.003	2.41 ± 0.006	0.0018	0.0027	178	5
C-S33-1000-030-2030	Agilent/Varian	1000	2.99 ± 0.003	2.41 ± 0.006	0.0018	0.0027	203	5
C-S33-0900-030-1780	Bruker	900	2.99 ± 0.004	2.41 ± 0.006	0.0020	0.0030	178	5
C-S33-0900-030-2030	Agilent/Varian	900	2.99 ± 0.004	2.41 ± 0.006	0.0020	0.0030	203	5
C-S33-0800-030-1780	Bruker	800	2.99 ± 0.005	2.41 ± 0.010	0.0025	0.0038	178	5
C-S33-0800-030-2030	Agilent/Varian	800	2.99 ± 0.005	2.41 ± 0.010	0.0025	0.0038	203	5
C-S33-0600-030-1780	Bruker	600	2.99 ± 0.006	2.41 ± 0.012	0.0040	0.0060	178	5
C-S33-0600-030-2030	Agilent/Varian	600	2.99 ± 0.006	2.41 ± 0.012	0.0040	0.0060	203	5
C-S33-0500-030-1780	Bruker	500	2.99 ± 0.010	2.41 ± 0.015	0.0050	0.0130	178	5
C-S33-0500-030-2030	Agilent/Varian	500	2.99 ± 0.010	2.41 ± 0.015	0.0050	0.0130	203	5
C-S33-0400-030-1780	Bruker	400	2.99 ± 0.013	2.41 ± 0.020	0.0070	0.0190	178	5
C-S33-0400-030-2030	Agilent/Varian	400	2.99 ± 0.013	2.41 ± 0.020	0.0070	0.0190	203	5
C-S33-0300-030-1780	Bruker	300	2.99 ± 0.025	2.41 ± 0.025	0.0070	0.0250	178	5
C-S33-0300-030-2030	Agilent/Varian	300	2.99 ± 0.025	2.41 ± 0.025	0.0070	0.0250	203	5
C-S33-0200-030-1780	Bruker	200	2.99 ± 0.030	2.41 ± 0.030	0.0100	0.0380	178	5
C-S33-0200-030-2030	Agilent/Varian	200	2.99 ± 0.030	2.41 ± 0.030	0.0100	0.0380	203	5

The Secure 55 Series™ NMR Sample Tubes for Routine NMR

The Secure 55 Series™ NMR tubes are made from ASTM Type I Class B borosilicate glass (“high expansion” borosilicate glass such as Kimble N-51A or equivalent) and parallel the properties of the Standard Series™ NMR tubes from Norell. These tubes are ideal for near room temperature analyses of routine samples exposed only to slight thermal gradients. Due to the larger coefficient of thermal expansion of this glass type, we do not recommend fusing these NMR tubes to glass vacuum manifolds or other glass laboratory apparatus, because these are usually constructed from low expansion borosilicate glass such as Pyrex® 7740. The dissimilar thermal expansion rates of the two glass types can result in cracking or breaking of the glass-to-glass seal.

5mm Ultra-Precision, High-Precision & Precision NMR Sample Tubes

Item No.	Spinner Turbine	MHz	O.D. (mm)	I.D. (mm)	Concentricity (mm)	Camber ±(mm)	Length (mm)	Packed In Lots Of
C-S55-1000-050-1780	Bruker	1,000	4.97 ± 0.004	4.20 ± 0.006	0.003	0.004	178	5
C-S55-1000-050-2030	Agilent/Varian	1,000	4.97 ± 0.004	4.20 ± 0.006	0.003	0.004	203	5
C-S55-0800-050-1780	Bruker	800	4.97 ± 0.005	4.20 ± 0.012	0.004	0.005	178	5
C-S55-0800-050-2030	Agilent/Varian	800	4.97 ± 0.005	4.20 ± 0.012	0.004	0.005	203	5
C-S55-0600-050-1780	Bruker	600	4.97 ± 0.006	4.20 ± 0.012	0.004	0.006	178	5
C-S55-0600-050-2030	Agilent/Varian	600	4.97 ± 0.006	4.20 ± 0.012	0.004	0.006	203	5
C-S55-0500-050-1780	Bruker	500	4.97 ± 0.013	4.20 ± 0.025	0.005	0.013	178	5
C-S55-0500-050-2030	Agilent/Varian	500	4.97 ± 0.013	4.20 ± 0.025	0.005	0.013	203	5
C-S55-0400-050-1780	Bruker	400	4.97 ± 0.013	4.20 ± 0.025	0.007	0.019	178	5
C-S55-0400-050-2030	Agilent/Varian	400	4.97 ± 0.013	4.20 ± 0.025	0.007	0.019	203	5
C-S55-0300-050-1780	Bruker	300	4.97 ± 0.025	4.20 ± 0.025	0.007	0.025	178	25
C-S55-0300-050-2030	Agilent/Varian	300	4.97 ± 0.025	4.20 ± 0.025	0.007	0.025	203	25
C-S55-00GS-050-1780	Bruker	300	4.97 ± 0.025	4.20 ± 0.025	0.010	0.038	178	25
C-S55-00GS-050-2030	Agilent/Varian	300	4.97 ± 0.025	4.20 ± 0.025	0.010	0.038	203	25
C-S55-0200-050-1780	Bruker	200	4.97 ± 0.030	4.20 ± 0.030	0.010	0.040	178	25
C-S55-0200-050-2030	Agilent/Varian	200	4.97 ± 0.030	4.20 ± 0.030	0.010	0.040	203	25



5mm Economy High-Throughput NMR Sample Tubes

Item No.	Spinner Turbine	MHz	O.D. (mm)	I.D. (mm)	Concentricity (mm)	Camber ±(mm)	Length (mm)	Packed In Lots Of
C-S55-0HTP-050-1780	Bruker	HT ^{PLUS}	4.97 ± 0.050	4.20 ± 0.050	0.020	0.070	178	50
C-S55-0HTP-050-2030	Agilent/Varian	HT ^{PLUS}	4.97 ± 0.050	4.20 ± 0.050	0.020	0.070	203	50
C-S55-00HT-050-1780	Bruker	HT	4.97 ± 0.050	4.20 ± 0.050	0.025	0.075	178	100
C-S55-00HT-050-2030	Agilent/Varian	HT	4.97 ± 0.050	4.20 ± 0.050	0.025	0.075	203	100

NorLOC™ Generation II Security Caps™ for 5mm & 3mm NMR Tubes

PAT8054080

The Next Generation of NorLoc™ NMR Tube Caps In A Rich Palette Of Fresh, Vibrant Colors

Advance to the next level of sample security, personal safety and time savings. Combine Norell NorLoc™ II Security Caps™ with Norell Secure Series™ NMR tubes and experience the ultimate sample containment system.

The standard 5mm and 3mm NMR tube cap designs have existed for decades. Many users can attest to the significant flaws inherent in the traditional NMR tube caps, especially when faced with the chore of capping numerous sample tubes.

The NorLoc™ II Security Caps™ feature an internal patent pending design improvement that not only addresses many of the flaws in the traditional NMR tube caps, but the superior design of the NorLoc™ II Security Cap introduces many substantial improvements not found in any other NMR tube caps.

The NorLoc™ II Security Cap™ can be applied much more easily and quickly, thereby increasing personal safety and saving valuable time. It incorporates an advanced dual seal design, conferring superior sealing and holding capabilities, especially when combined with a Secure Series™ or other Norell NMR tube having the Security Band™ which interlocks with the NorLoc™ II Security Cap™.

This interlocking capability results in superior retention of the cap to the NMR tube, forming a “vaulted seal” that not only increases the barrier capability when used with any NMR tube, but the locking interaction prevents the occurrence of NMR tube and cap separation, safeguarding precious or critical samples, even during refrigerated cold storage, variable temperature cycling or repeated cap removals and reapplications.

The patent pending design of the NorLoc™ II Security Cap™ includes an expanded entryway, or guide section, in the opening of the cap, to help align and start the placement of the cap on the NMR tube. Adjacent to this, a constriction within the cap forms a tight, effective seal against the wall of the NMR tube, followed by a second constriction that functions in a like manner to form a dual seal. Finally, the innermost region expands slightly in diameter, allowing the NMR tube to slip easily through to the end, creating a positive indication of proper placement and “lock”, ensuring a “vaulted seal” every time.

In addition, the upper, straight edge of the patent pending marking or label area on Secure Series™ or other Norell NMR tubes functions as a clear visual indicator, defining the limit for full and complete closure with the NorLoc II Security Cap™.

When preparing dozens, or even hundreds, of samples for analysis, tube capping can consume a significant amount of time. The traditional cap must first be held at an angle to the NMR tube to start placement of the cap, and then must be stretched and twisted onto the tube. This becomes a tedious exercise after capping a few dozen tubes, and often results in caps that are tilted and misshapen afterwards, promoting poor seals and split caps. This process also creates significant mechanical stress in the glass NMR tube, and can frequently lead to broken tubes, spilled sample and worse, including cuts or other injuries.

With the NorLoc™ II Security Cap™ however, the NMR tube easily enters the expanded guide section, and thereafter becomes self-aligning, allowing the cap to be simply pushed straight onto the tube. This method takes advantage of the compressive strength of glass, while minimizing the common causes of glass fracture from radial and torsional stresses induced in the glass from stretching and twisting traditional caps onto the NMR tube at an angle.

Proper, trouble-free closure of NMR tubes is ensured by the combination of NorLoc™ II Security Caps™ with Secure Series™ or other Norell NMR tubes, creating a “vaulted seal” that resists tube and cap separation even with troublesome NMR solvents such as chloroform-d, providing precise, uniform cap positioning and seal integrity, safeguarding critical and precious samples against losses caused by evaporation, contamination or degradation due to atmospheric exposure.

NorLOC™ Series... Ingenuity, Precision, Proven Results

PAT8054080

Patented Design with Superior Holding & Sealing Capabilities

NorLOC™ The New Standard for NMR Tube Caps

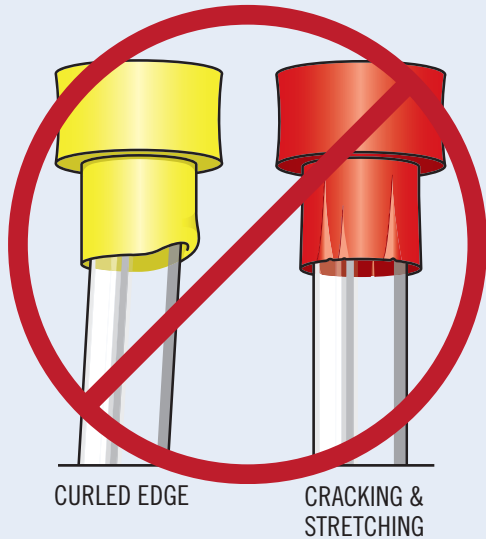
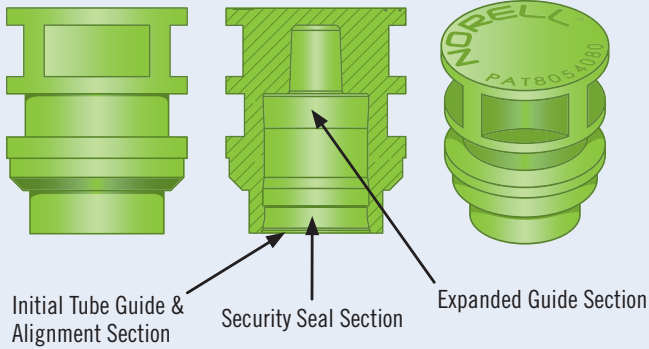

Item No.	Cap Color	Size	Available in Lots of
C-NORLOC2-5-PA	Purple Acai	5 mm	100
C-NORLOC2-5-GW	Glacier White	5 mm	100
C-NORLOC2-5-B0	Black Onyx	5 mm	100
C-NORLOC2-5-MJ	Mint Julep	5 mm	100
C-NORLOC2-5-LY	Lemon Yellow	5 mm	100
C-NORLOC2-5-BH	Blue Harbor	5 mm	100
C-NORLOC2-5-SG	Sea Glass	5 mm	100
C-NORLOC2-5-RP	Red Poppy	5 mm	100
C-NORLOC2-5-OT	Orange Tangerine	5 mm	100
C-NORLOC2-5-PS	Pink Sorbet	5 mm	100
C-NORLOC2-5-GE	Green Envy	5 mm	100
C-NORLOC2-5-BR	Blue Royal	5 mm	100
<hr/>			
C-NORLOC2-3-PA	Purple Acai	3 mm	100
C-NORLOC2-3-GW	Glacier White	3 mm	100
C-NORLOC2-3-B0	Black Onyx	3 mm	100
C-NORLOC2-3-MJ	Mint Julep	3 mm	100
C-NORLOC2-3-LY	Lemon Yellow	3 mm	100
C-NORLOC2-3-BH	Blue Harbor	3 mm	100
C-NORLOC2-3-SG	Sea Glass	3 mm	100
C-NORLOC2-3-RP	Red Poppy	3 mm	100
C-NORLOC2-3-OT	Orange Tangerine	3 mm	100
C-NORLOC2-3-PS	Pink Sorbet	3 mm	100
C-NORLOC2-3-GE	Green Envy	3 mm	100
C-NORLOC2-3-BR	Blue Royal	3 mm	100

Note: Caps are available in 500 and 1000 piece packages. Please contact us for details.



Distributed By



3800 North Mill Road
Vineland, NJ 08360

Phone: (800)-843-1794

Fax: (800)-922-4361

E-mail: info@cglifesciences.com
tech@cglifesciences.com
quotes@cglifesciences.com

Website: www.chemglass.com

NorLOC™

GENERATION II

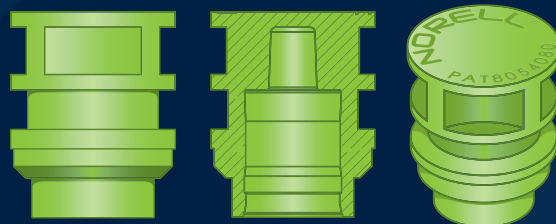

The Next Generation NMR Tube Caps In A Rich Palette of Fresh, Vibrant Colors

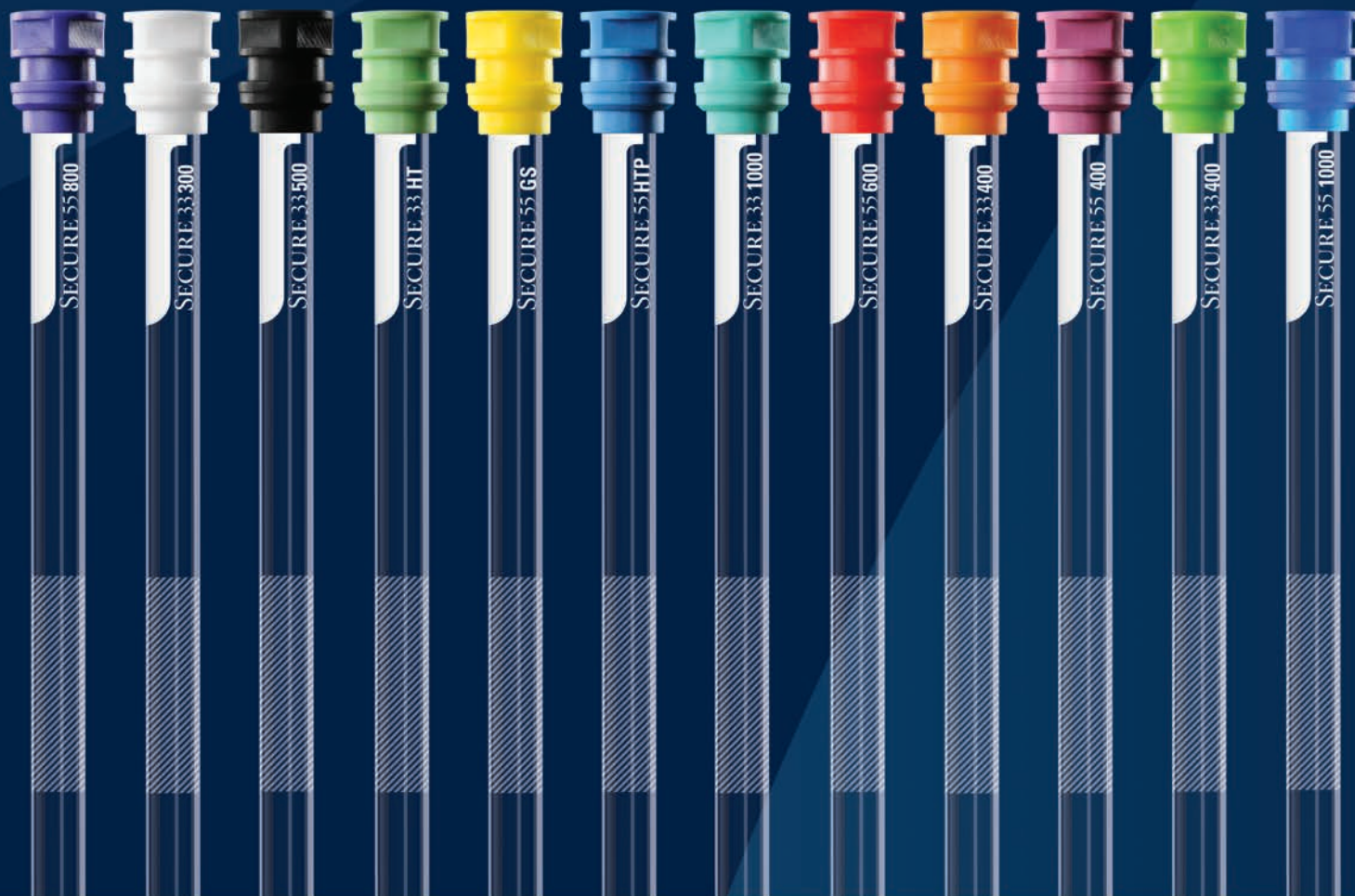

SINCE 1967
Celebrating 51 Years of Precision

Printed in United States of America
Copyright ©2016 NORELL®
No. 3.29.18